

# PRODUCT FOCUS



## Screw Conveyor

### Simple and economical

The new SEW-EURODRIVE Screw Conveyor Drive is ready to be put to work! SEW's re-designed screw conveyor drive now boasts a 50% higher axial load capacity, labyrinth sealing technology, and design features for ease of maintenance. Using the SEW shaft removal tool, even the most stubborn shaft can be removed with little effort. Gear unit and seal maintenance is streamlined, as the sealed



CEMA flange takes the screw load while the gear unit is removed, minimizing the need for trough access and screw removal. All of these features coupled with the proven and reliable SEW gearmotor, make the new SEW Screw Conveyor Drive an

ideal solution for bulk material handling applications.

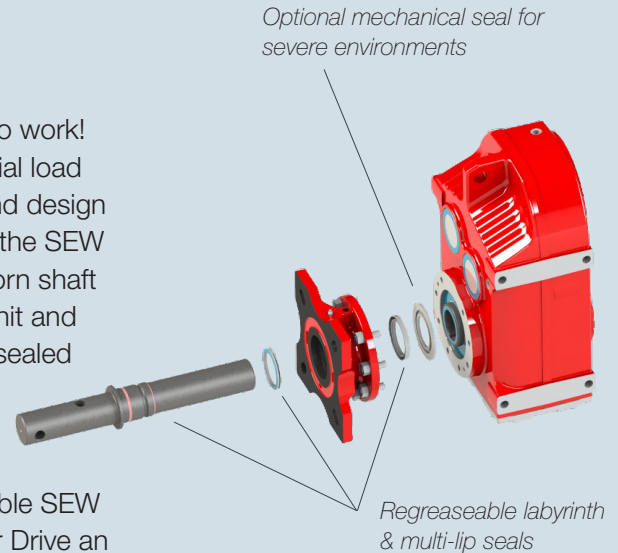

### Benefits at a Glance

- Increased L10 bearing lifetime and higher axial load capability
- Superior sealing performance
- Able to operate in abrasive environments
- Reduced downtime and maintenance
- Flexible configuration
  - Available with FAZ (parallel) or KAZ (right angle) gear units
  - Integrated gearmotor, motor platform or IEC/NEMA motor adapter
  - 2 Hole or 3 Hole Shaft (stainless optional)

### Variety of motor configurations available

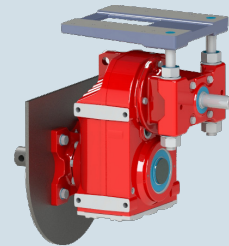

Reinforced bearings as a standard

### Screw Conveyor drive configurations

Size	CEMA Drive Shaft (2 Hole or 3 Hole)				
	1-1/2"	2"	2-7/16"	3"	3-7/16"
FAZ/KAZ 37	√	-	-	-	-
FAZ/KAZ 47	√	√	-	-	-
FAZ/KAZ 57	√	√	√	-	-
FAZ/KAZ 67	√	√	√	√	-
FAZ/KAZ 77	-	√	√	√	-
FAZ/KAZ 87	-	-	√	√	√
FAZ/KAZ 97	-	-	-	√	√

\* See SEW-Eurodrive's Gearmotor catalogue for drive selection tables

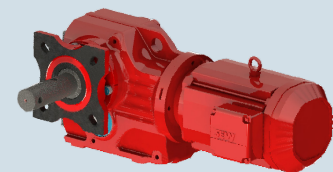

Easy access design minimizes trough and screw disturbance

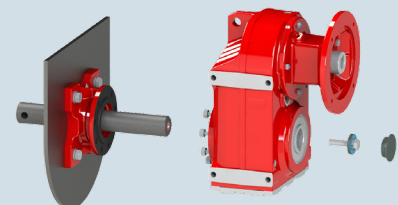

SEW shaft removal tool makes for trouble free disassembly



#### Ontario

SEW-Eurodrive  
210 Walker Drive  
Bramalea, ON L6T 3W1  
Telephone: (905) 791-1553  
Fax: (905) 791-2999

#### Quebec

SEW-Eurodrive  
2555 rue Leger  
Lasalle, QC H8N 2V9  
Telephone: (514) 367-1124  
Fax: (514) 367-3677

#### British Columbia

SEW-Eurodrive  
7188 Honeyman Street  
Tilbury Industrial Park  
Delta, BC V4G 1G1  
Telephone: (604) 946-5535  
Fax: (604) 946-2513

## About SEW-Eurodrive

Our product is motion. Our focus is solutions.

As a worldwide supplier of innovative gearing, motor, and electronic drive technology, we

have been solving problems in large and small applications within virtually every industry for over 85 years.

We also specialize in reducing the total cost of ownership with our customer-specific energy saving solutions.

Globally, we have assembly centers in 44 countries, along with 15 production plants. Therefore, we are able to provide uniform quality standards and international application experience.

Locally, we provide final assembly and custom modifications plus assistance with project planning, startup, and training. All products are backed by our industry-leading 24/7 support program.

**SEW-Eurodrive ... Driving the world**

Local website: [www.sewcan.ca](http://www.sewcan.ca)  
Corporate website: [www.sew-eurodrive.ca](http://www.sew-eurodrive.ca)

